

# RANGER® 330MPX™

## Welder/Generator



Shown:  
Ranger 330MPX (K3459-1)

## KEY FEATURES

The Ranger 330MPX welder/generator leads the way for the construction, maintenance, and service truck industries. The modern design and advanced features allow this machine to streamline welding operations and improve efficiency at the job site. This low-decibel machine helps keep your work environment comfortable while still being able to perform every job. Increase productivity with the Ranger 330MPX welder/generator's new technology:

- Easy-to-Use Digital User Interface
- Full Suite of Smart Features
- Clean AC Generator Power



### Processes »

Stick, MIG, TIG, Flux-Cored,  
& Gouging

### Output »



### Input »



### Applications »

Construction  
Maintenance & Repair  
Service Truck  
Rental  
Pipeline Welding

### Product Number »

K3459-1 Ranger 330MPX

## ADVANCED FEATURES

- » Enhanced remote control capabilities offer operators the ability to select their preferred remote amperage scale without additional cables
- » Enable the supervisor and operator passcode protection to lock settings and weld modes
- » The maintenance screens allows the machine to record engine hours for proper service and maintenance

## SMALLER SIZE

- Up to 20% smaller footprint than other machines in its class
- Up to 25% lighter making it easier to maneuver around the job site
- Up to 31% smaller in volume than other machines in its class

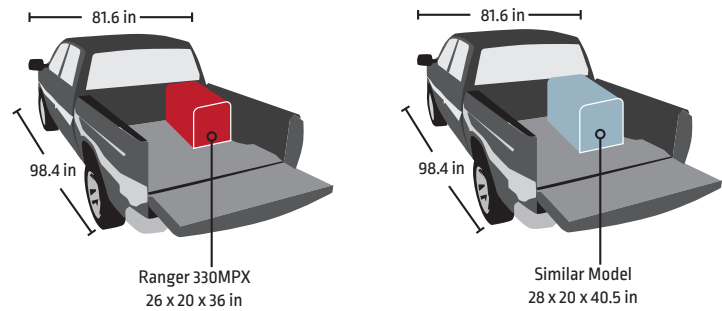

## QUIETER SOUND

- Up to 60% quieter than other machines in its class
- Engineered to enhance operator comfort and safety

## SMARTER MACHINE

### PERFORMANCE-BOOSTING TECHNOLOGY

Ready.Set.Weld® intuitive push-and-turn digital controls make setup a breeze



ArcFX™ technology provides instant graphical feedback on how settings affect the weld outcome



The Chopper Technology® feature provides easy starts, a smooth and consistent arc, and low spatter for optimal bead appearance



CrossLinc® remote technology communicates voltage control to the welding power source through one common weld cable



## HIGH QUALITY OPERATIONS

- Clean AC generator with 10 kW of continuous, consistent power to keep tools running without interruptions
- New engine driven weld modes: downhill pipe, touch-start pulse TIG, and pulse spool gun
- Plenty of power at 330A/28V for 100% duty cycle to weld 1/4 in. 7018 electrode
- Fine tune adjustments available on: Hot start, arc force, and pinch controls
- Arc gouging capabilities up to 3/64" carbon electrode

## NEW BOLT PATTERN MOUNTING SPECIFICATIONS BASE VIEW

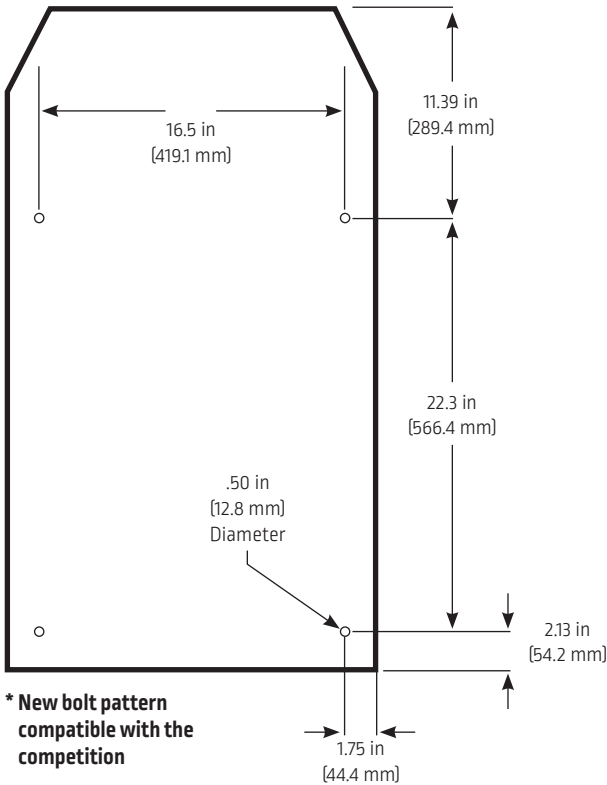

## MAGNUM PRO® 250LX GT SPOOL GUN



The Magnum PRO 250 LX GT Spool Gun is the first direct connect spool gun in its class to provide a cost saving solution with no additional accessories required

## KEY CONTROLS

1. Amps
2. Fuel Gauge
3. Weld Mode
4. Home Button
5. Local/Remote Button
6. Output
7. Advanced Weld Feature w/ ArcFX Technology
8. Ready.Set.Weld. Parameters
9. Back Button
10. Help Button



## KEY CONTROLS

1. Digital User Interface
2. Engine Choke Control
3. GFCI
4. 120/240 Volt AC Full KVA Receptacle
5. Output Studs
6. Front battery access for easy maintenance
7. Engine Start Switch
8. Scroll Knob
9. 240 Volt AC Receptacles
10. Ground Stud
11. 120 Volt AC Receptacles
12. Galvanized base to increase the life of the machine and prevent rusting
13. Strain relief shackles for improved life on cables

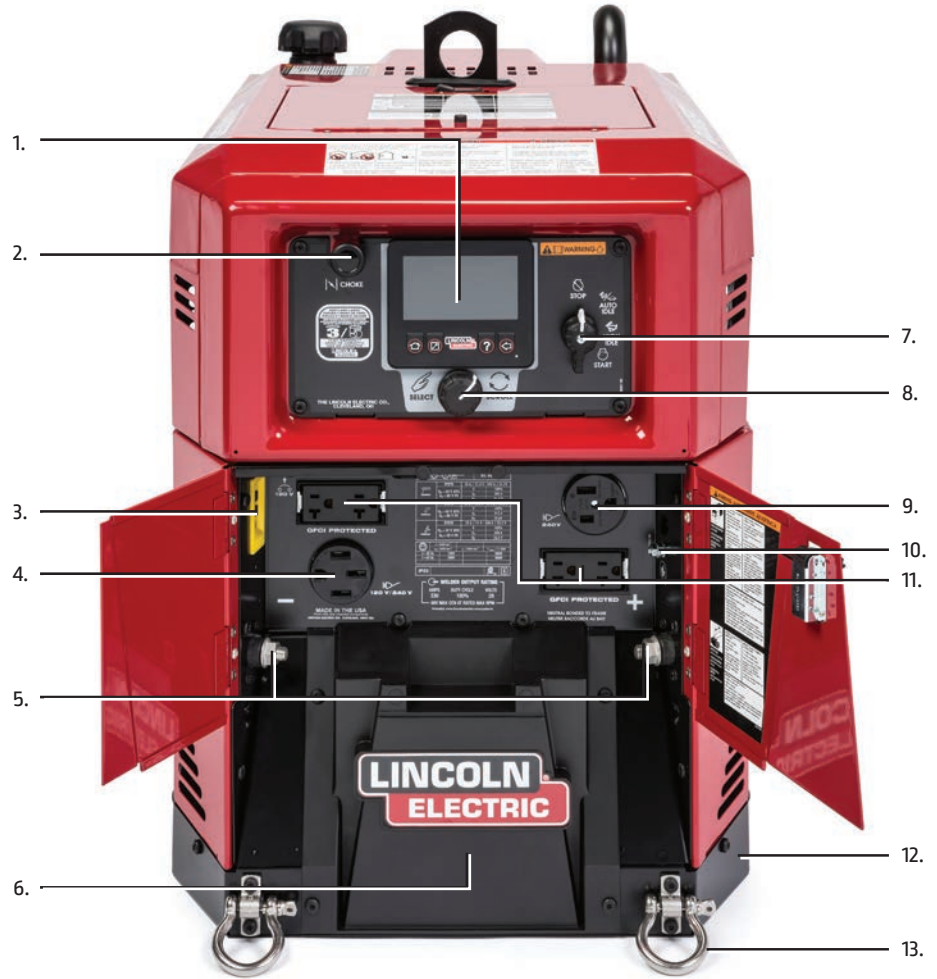

14. 6pin connector for easy to connect remote control operations, or foot or hand amptrol
15. Circuit Breakers
16. 7 pin connector for the first in class direct connect spool gun

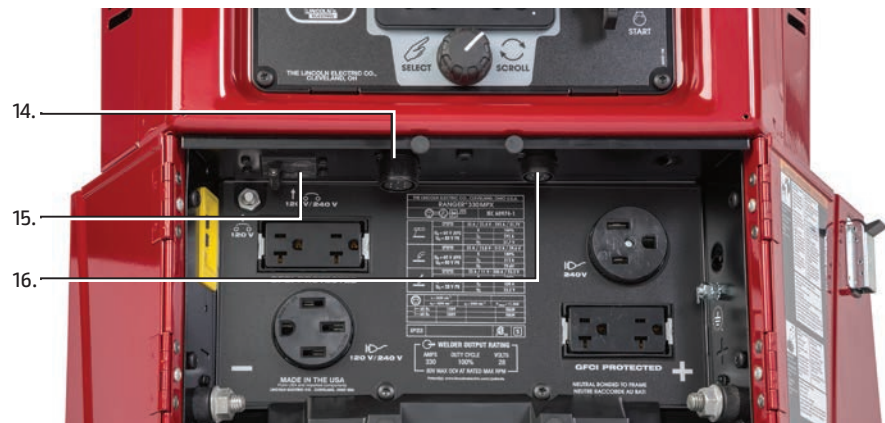



## RECOMMENDED ACCESSORIES

### POWER SOURCES



**Square Wave TIG 200**  
A TIG welder that includes AC frequency controls and AC balance for great results on aluminum.  
Order K5126-1



**Power MIG® 210 MP**  
A multi-process CV and CC welder provides easy to use interface to help achieve consistent weld performance.  
Order K3963-1



**Power MIG 180C**  
Compact CV wire welder for MIG and flux-cored welding.  
Order K2473-2



**Tomahawk® 1000**  
Portable plasma cutter for fast and precise metal cutting.  
Order K2808-1

### WIRE FEEDERS



**Activ8X™**  
Compact wire feeder providing simple controls and across-the-arc operations.  
Order K3519-1



**LN-25X™**  
Portable, easy to set, and reliable wire feeder with CrossLinc® Technology.  
Order K4267-1



**LN-25X / Magnum PRO Curve™ 045C One-Pak**  
Wire Feeder Includes: LN-25X Feeder, Magnum® PRO Curve™ welding gun Ready-Pak®, .040-.045 in. (1.0-1.2 mm) Cored Wire Drive Roll Kit.  
Order K4100-1



**LN-25X / K126® PRO 1/16-5/64C One-Pak**  
Wire Feeder Includes: LN-25X Wire Feeder, K126™ PRO Innershield® 350A FCAV-SS Welding Gun, 5/64 in. (2.0mm) Solid/Cored Wire Drive Roll Kit, 1/16 in. (1.6mm) Cored Wire Drive Roll Kit.  
Order K4100-2



**Magnum 250 LX GT Spool Gun**  
A quick-connect hand held semiautomatic wire feeder for welding 1lb spools.  
Order K3569-2



**Adjustable Gas Regulator & Hose Kit**  
A gas regulator for CO<sub>2</sub>, Argon, and Argon blends. Kit includes: Pressure gauge, dual scale flow gauge, and 4.3 ft. (1.3mm) gas hose.  
Order K586-1



### STICK OPTIONS

**Accessory Kit**  
400 amp nominal rating stick welding kit with: electrode holder, work clamp, 35' 2/0 cables, helmet, & electrode holder.  
Order K704



**Accessory Kit**  
For stick welding. Includes 20 ft. (6.1 m) #6 electrode cable with lug, 15 ft. (4.6 m) #6 work cable with lugs, headshield, filter plate, work clamp, electrode holder and sample pack of mild steel electrode. 150 amp capacity.  
Order K875



**Remote Control Kit**  
A control box allowing adjustable output from varying cable lengths.  
Order:  
K857-1 for 100ft  
K4330-1 for 125ft  
K4268-1 for 125ft with 115VAC receptacle



**CrossLinc Remote**  
A Remote control added in-line with the welding power cable allowing remote output control of the power source through the weld cable for Stick, TIG and Gouging processes  
K4345-1



### TIG OPTIONS

**Pro-Torch™ PTA-26 TIG Torch**  
Air-cooled 200 amp torch (2 piece separate power conductor and a braided gas hose).  
Order K1783-4



**Magnum Parts Kit for PTA-26V**  
Provides all the torch accessories to start welding. Kit includes: collets, collet bodies, a back cap, alumina nozzles, and tungsten in a variety of sizes.  
Order KP509



**Foot Amptrol**  
Provides 25ft. of adjustable weld current based on the applied pressure on the pedal, great for making critical TIG welds and crater filling.  
Order K870



**Wireless Foot Amptrol**  
Wireless foot pedal, great for making critical welds and crater filling remotely.  
Order K4217-1



**Hand Amptrol**  
Provides 25ft of remote current control through a handheld regulator.  
Order K963-3



**TIG Module**  
Portable, high frequency unit with gas valve for TIG welding. Rated at 300 amps/60% duty cycle.  
Order K930-2



**TIG Module Cable**  
Connects TIG Module to the power source with a 9-pin connector to a 6-pin connector.  
Order K936-3



Shown with optional K2639-1 Fender & Light Kit

### TRAILERS AND UNDERCARRIAGES

**Small Two-Wheeled Road Trailer**  
Two-wheeled trailer with a standard Duo-Hitch™ for heavy-duty road, off road, plant and yard use. Includes pivoting jack stand, safety chains and 13in wheels.  
Order:  
K2635-1 Trailer  
K2639-1 Fender and light kit  
K2640-1 Cable Rack



**All Terrain Undercarriage**  
Portable cart for the moving the engine drive by hand over construction sites with heavy-duty puncture resistant tires.  
Order K3590-1



**Factory Undercarriage**  
Portable cart for the moving the engine drive by hand over smooth surfaces with heavy-duty puncture resistant tires and swivel castors.  
Order K3589-1



### ADDITIONAL ACCESSORIES

**Power Plug Kit**  
Provides four 120V plugs rated at 20 amps each, and one dual voltage, full KVA plug rated at 120/240V, 50Amps.  
Order K802N



**Spark Arrestor**  
Attaches to muffler exhaust tube and virtually eliminates spark emissions.  
Order K3679-1



**Ballistic Nylon Cover**  
A flame retardant, mildew resistant, and water repellent cover to protect the engine drive when not in use.  
K3588-1



**Kohler® Tune-Up Kit**  
Engine maintenance kit includes: Spark plugs, in-line fuel filter, air filter pre-cleaner, oil, and oil filter.  
K3494-1

## MACHINE SPECIFICATIONS

Product Name	Ordering Information	Description	CC Rated Output Current/ Voltage/ Duty Cycle	CV-Rated Output Current/ Voltage/ Duty Cycle	Generator AC Power <sup>(2)(3)</sup>	Dimensions H x W x L inches (mm)	Weight lbs. (kg)
Ranger 330MPX	K3459-1 Painted Roof, Case Sides and Engine Doors	330 Amp DC Mult- Process Arc Welder with Chopper Technology	DC Constant Current 330A/28V/100%	DC Constant Voltage <sup>(1)</sup> 312A/29V/100%	11,500 Watts Peak	26 x 20 x 36 (660 x 508 x 914)	446 (202)
		11,500 Watts Peak AC Power	DC Pipe Current 330A/28V/100%		10,000 Watts Continuous 60 Hz Single Phase		
		10,000 Watts Continuous AC Power	Touch Start TIG 330/23.2/100%		Full KVA Receptacle 42A @ 240V 40A @ 120V ea. Branch Circuit <sup>(4)</sup>		
					Four 120V Receptacles 20A Total <sup>(4)</sup>		

<sup>(1)</sup> DC constant voltage capability provides convenience and added safety when welding in electrically hazardous conditions.

<sup>(2)</sup> When welding, available auxiliary power will be reduced. Output voltage is within +/- 10% at all loads up to rated capacity.

<sup>(3)</sup> 120V will operate either 60 Hz or 50/60 Hz power tools, lights, etc.

<sup>(4)</sup> Circuits cannot be wired in parallel to operate the same device.

## ENGINE SPECIFICATIONS

Engine Model	Description	Horsepower & Displacement	Ignition	Capacities	Operating Speeds	Fuel Consumption
Kohler OHV <sup>(3)</sup> Command CH740 Gasoline	2 Cylinder, 4 Cycle, OHV, Air-Cooled Gasoline Engine Aluminum Alloy Block with Cast Iron Liners Electric Fuel Pump	25 HP @ 3600 RPM 44.2 cu in (725 cc)	Electric Start, 12V Group 99 Battery, 410 Cold Cranking Amps, Rotary Start Switch	FUEL: 11 Gals (41.6 liters) OIL: 2.0 Qts (1.9 liters)	FULL LOAD 3,600 RPM	1.6 Gals/Hr 6.1 liters/Hr
					HIGH IDLE 3650 RPM	0.8 Gals/Hr 3.1 liters/Hr
					LOW IDLE 2,400 RPM	0.6 Gals/Hr 2.1 liters/Hr

<sup>(3)</sup> Kohler warranty is 3 years.

## PRODUCT SPECIFICATIONS

Product Number	Engine	Rated Output Current /Voltage/Duty Cycle	AC Generator Power Output	Capacities	Dimensions	Noise At Full Load (dBA)	Net Weight lb (kg)
K3459-1	Kohler OHV CH740	NON-IEC Rating: Maximum Output: 330A/28V/100%  IEC Rating: DC Stick: 292A/31.7V/100% DC TIG: 330A/23.2V/100% DC Constant Voltage: 312A/ 29.6V 100%	1-Ph/AC Power: 10 kW Continuous 11.5 kW Peak	Fuel: 11 gal. Oil: 2.0 qts	26 x20 x36 (660 x 508 x 914)	74.7 dBA	446 (202)

For best welding results with Lincoln Electric equipment, always use Lincoln Electric consumables. Visit [www.lincolnelectric.com](http://www.lincolnelectric.com) for more details.

Manufactured at a facility with certified ISO Quality and Environmental Management Systems.

All trademarks and registered trademarks are the property of their respective owners

## CUSTOMER ASSISTANCE POLICY

The business of The Lincoln Electric Company is manufacturing and selling high quality welding equipment, consumables, and cutting equipment. Our challenge is to meet the needs of our customers and to exceed their expectations. On occasion, purchasers may ask Lincoln Electric for information or advice about their use of our products. Our employees respond to inquiries to the best of their ability based on information provided to them by the customers and the knowledge they may have concerning the application. Our employees, however, are not in a position to verify the information provided or to evaluate the engineering requirements for the particular weldment. Accordingly, Lincoln Electric does not warrant or guarantee or assume any liability with respect to such information or advice. Moreover, the provision of such information or advice does not create, expand, or alter any warranty on our products. Any express or implied warranty that might arise from the information or advice, including any implied warranty of merchantability or any warranty of fitness for any customers' particular purpose is specifically disclaimed.

Lincoln Electric is a responsive manufacturer, but the selection and use of specific products sold by Lincoln Electric is solely within the control of, and remains the sole responsibility of the customer. Many variables beyond the control of Lincoln Electric affect the results obtained in applying these types of fabrication methods and service requirements.

Subject to Change – This information is accurate to the best of our knowledge at the time of printing. Please refer to [www.lincolnelectric.com](http://www.lincolnelectric.com) for any updated information.



The Lincoln Electric Company  
22801 St. Clair Avenue · Cleveland, OH · 44117-1199 · U.S.A.

[www.lincolnelectric.com](http://www.lincolnelectric.com)